



Gold Coast  
Blinds  
& Shutters

# HOW TO INSTALL PLANTATION SHUTTERS

[www.gcblindsandshutters.com.au](http://www.gcblindsandshutters.com.au)

# BEFORE YOU BEGIN

---

Your shutters will arrive in separate parcels. The longer and slimmer parcel will contain the sections of the frame and the flatter rectangular parcel will contain the panels.

A maximum of two panels will be packed together, so for wider sets of shutters there will be additional parcels containing the additional panels.

The fixing kit will be packed in the frame parcel.

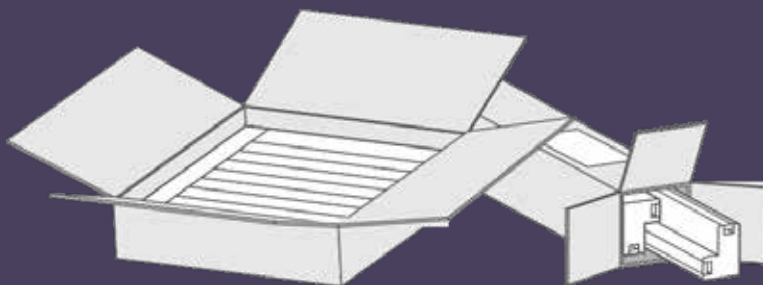

# YOUR FIXING KIT

---

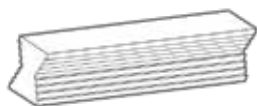

4 x Hoffman Keys

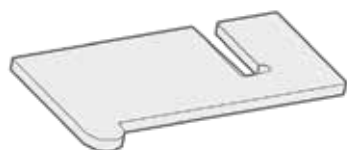

4 x Frame Packing Shim



8 x 75mm Screws



8 x 20mm Screws



4 x Hinge Packing Shim



# 1. ASSEMBLE THE FRAME

Start by unpacking all of the frame pieces, then laying them face-down.

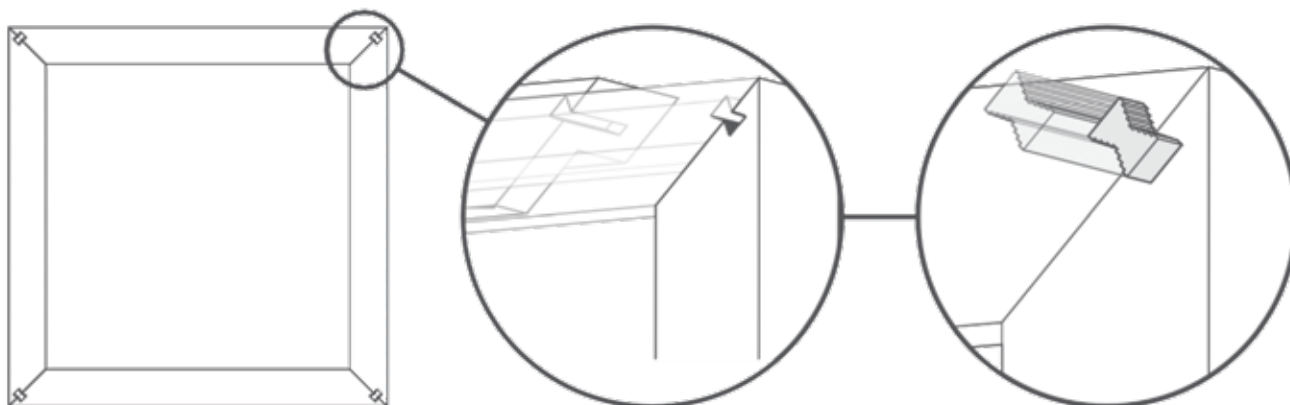

Line up all the corners, then insert the Hoffman keys from your fittings kit to join the frames securely together. The key can be a little tight, so you may have to give it a few taps with a hammer to fully insert it.

## Top Tip

Use the packaging your shutters arrived in to protect them during this stage - open out one of the boxes so you can lay the shutter down on that and avoid any risk of scratching it. Like wise, you may need to gently hammer the hoffman keys into place as they're quite tight, so you can use a strip of cardboard over the key as you're hammering.

**Wider shutters over 1850mm will have a 'T-Bar' provided with the frame.**

The T-Bar is fitted vertically in the centre of the frame, providing extra support for the shutter.

To fit the T-Bar, simply slot it into place in the centre of the shutter and use 4 of the 75mm screws provided - 2 at the top of the frame and 2 at the bottom - to secure it in place. The screw holes will be pre-drilled in your shutter frame so that the T-Bar can be located correctly and easily.

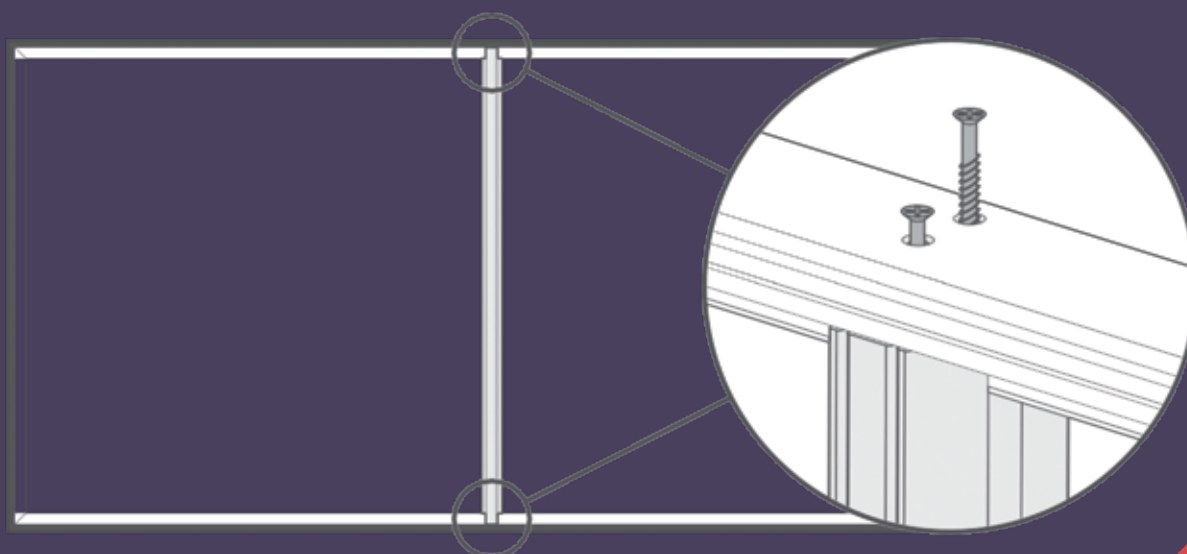

## 2. PRE-DRILL THE FIXING HOLES IN THE FRAME

Assemble the frame, then drill the holes you'll be putting screws through to fit the shutter. For the sides, make your holes roughly in line with the centre of each hinge. For the top and bottom, make the holes roughly 10-15cm in from the sides.

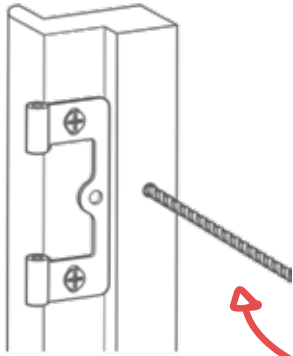

For 'Recess' fitting, drill through the thicker section toward the back of the frame.

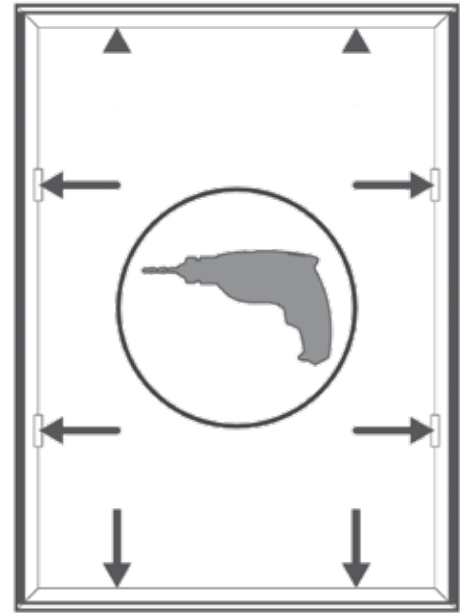

## 3. ENSURE THE FRAME SITS LEVEL IN THE WINDOW

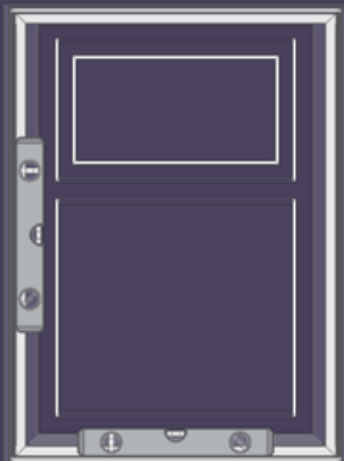

Place the assembled frame in the recess and use a spirit level to make sure that it is sitting perfectly straight on all sides.

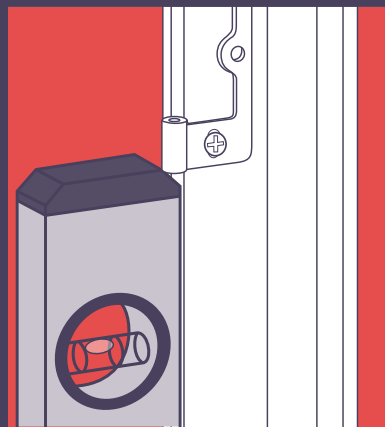

Make sure you also use the spirit level on the front of the frame, on all sides, to ensure there's no 'twist' to the frame.

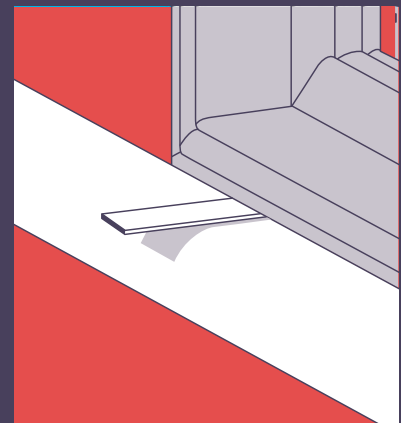

If you need to adjust the level of the frame then you can use the frame shims from your fitting kit. Fully insert the shim so that it is hidden by the frame.

## 4. INSTALL THE FRAME

Making sure that the frame stays still and level, push the drill through each of the fixing holes you made in the frame and drill a small pilot hole in the surface you're fixing the shutter to (the inside of the recess). Drill through the plaster as far as the timber beneath. You should now be left with shallow pilot holes all around the recess - two for each side, the top and the sill.

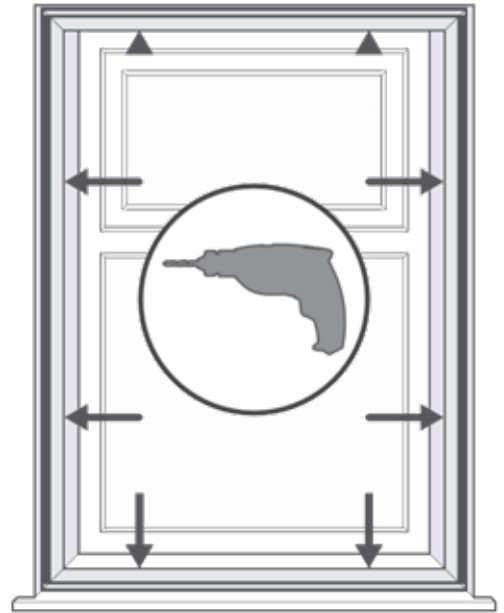
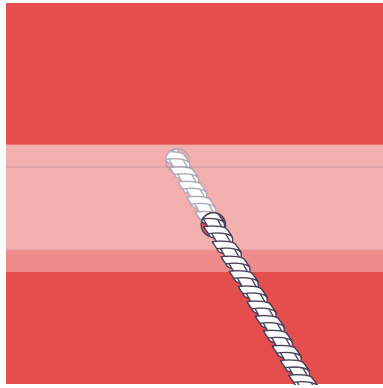

### Top Tip

While drilling your pilot holes, be sure to keep checking your frame is straight, using your spirit level. Check the level again before drilling each pilot hole.

Give the frame another level check, then use the 75mm screws from your fixing kit to secure the frame in place.

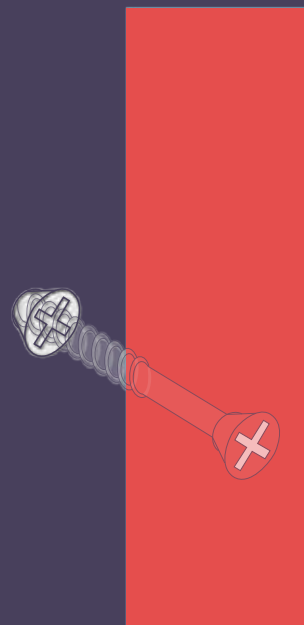
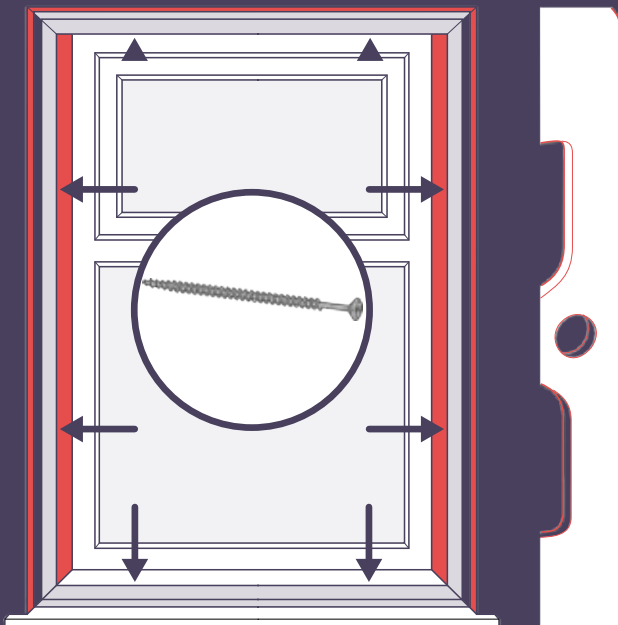

### Top Tip

Insert the screws for the top part of the frame first, to help hold it steady while you insert the rest of the screws.

## 5. INSTALL THE PANELS

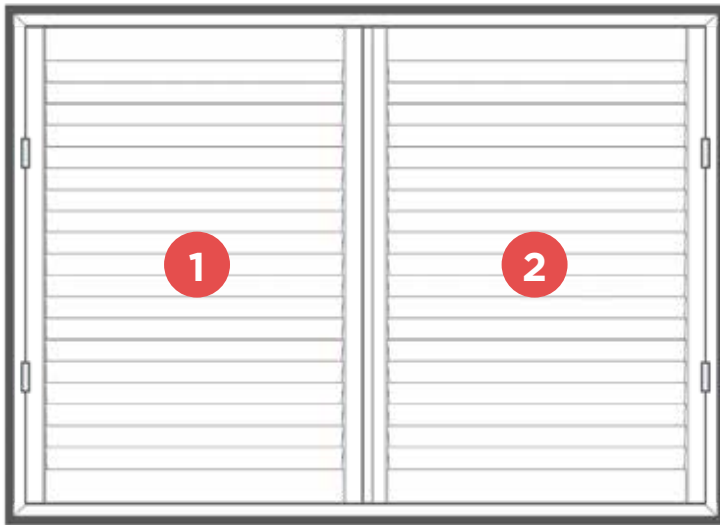

Your shutter panels are numbered in order of their position in the shutter, with panel 1 being the far left side.

### Top Tip

Ensure that your panels are not fitted upside down - look for the lip on the top bar of the panel, the lip should be at the back, facing you.

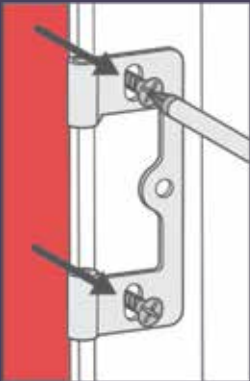

Start by loosening the frame hinges, as this will make aligning the two parts of the hinge easier (one part is fixed to the frame, the other part is fixed to the panel). This will also allow you enough room to slot the hinge pins into place.

Now slot the hinge pins into place. Starting with the top hinge on each panel, align the panel part of the hinge with the frame part of the hinge, then insert the pin through the centre. If your shutter has folding panels, join these together the same way.

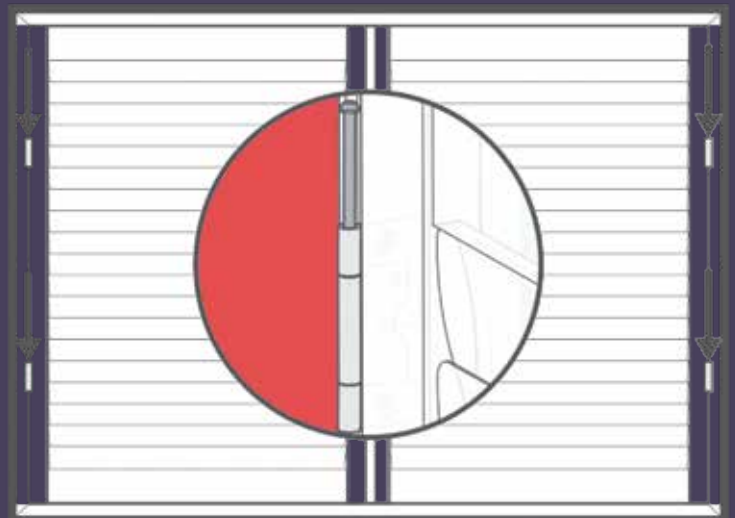

### Top Tip

The pins are intentionally a tight fit. Place a piece of cloth or cardboard over the top of the pin (to prevent it getting scratched or marked) and use a small hammer to tap it securely into place.



## 6. FINE TUNING

Because no recess is perfectly square, you'll likely find that some adjustments are required to align the panels (i.e. if one panel sits slightly higher than the other), although thorough checks with your spirit level throughout the installation process should help to minimise the amount of fine tuning required.

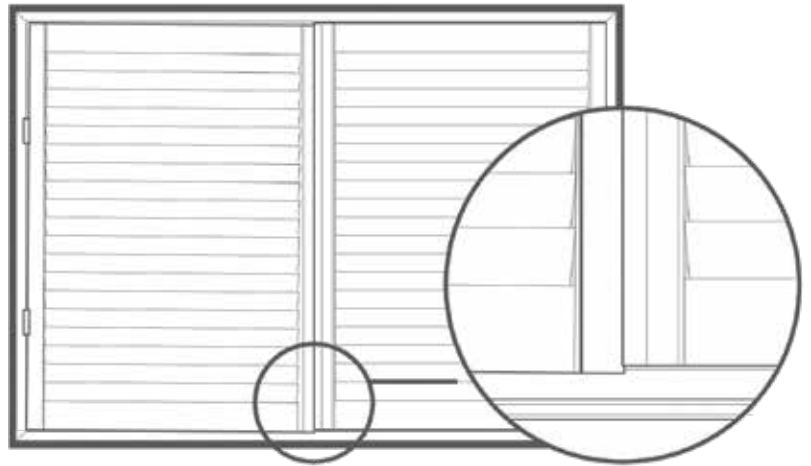

### Top Tip

It is normal for the panels to rest on the bottom frame of the shutter when closed, this does not require any adjustment.

The best method for adjusting the level of the panels is actually to adjust the frame. If one panel sits higher than the other, go to the side which is sitting lowest and loosen the frame screws on that side, and along the bottom. Then insert one of the frame shims from your fixing kit to raise that side slightly. This should level out the panels.

Various sizes of frame shims are supplied to allow you to make very fine adjustments.

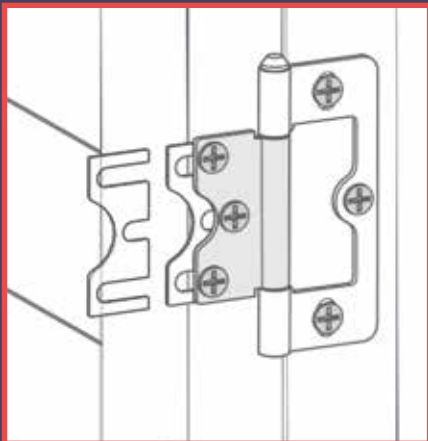

If you've levelled the frame out as much as you can but the panels are still uneven, then you can use a hinge shim.

Only use one shim, either on the highest panel hinge or the lowest.

Use a shim at the top of the panel to lower the panel alignment, or at the bottom to raise it.

## 7. FINISHING

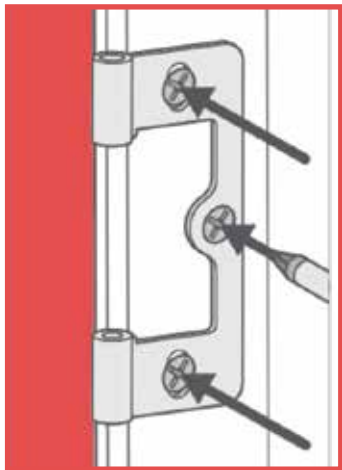

Tighten the hinge screws and insert a final screw in the centre hole for each frame hinge, to lock the hinges in place.

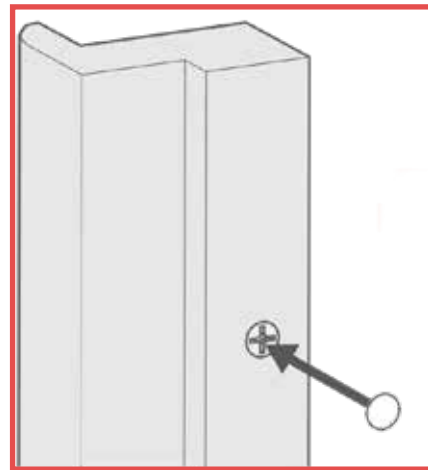

Finally, cover the screws you used to fix the frame inside the recess. Use the supplied screw covers to cover the screws.

### Top Tip

As a final finishing touch, use decorator's caulk to fill in any gaps around the edges of the frame (usually only required for Inside Recess Frames).

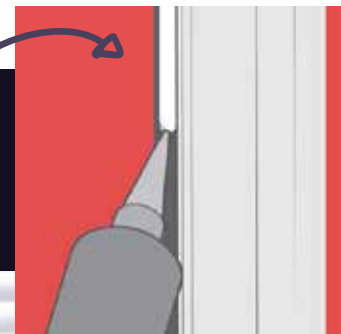





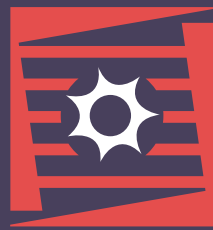

Gold Coast

Blinds  
& Shutters

[www.gcblindsandshutters.com.au](http://www.gcblindsandshutters.com.au)